

## Hardy Rollen Garantie

Alle Hardy Wide Spool Perfect Rollen besitzen eine eingeschränkte 5 Jahres Garantie, die folgenden Bedingungen unterliegt

- Wir garantieren, dass das Produkt frei von Fehlern in Material, Design und Verarbeitung ist. Gültig für einen Zeitraum von 5 Jahren ab Kaufdatum (gilt nur für Erstbesitzer).
- Diese Garantie gilt zusätzlich zu gesetzlichen Regelungen in Bezug auf fehlerhafte Produkte oder fehlerhafte Beschreibung.
- Voraussetzung für diese Garantie ist die Registrierung der Rolle innerhalb 60 Tagen nach dem Kauf unter: [www.hardyfishing.com](http://www.hardyfishing.com). Sie erhalten eine E-Mail zur Bestätigung der Garantie. Bewahren Sie den Kaufbeleg gut auf, da er bei Reklamationen vorgelegt werden muss.
- Die Garantie deckt keine Schäden ab, die verursacht wurden durch: Missbrauch, mangelnde Pflege, Verlust, normale Abnutzung durch Gebrauch und Verschleiß.
- Für weitere Details zur Garantie, den Reklamations-Ablauf oder Ausnahmen, besuchen Sie bitte [www.hardyfishing.com](http://www.hardyfishing.com). Bei Reklamationen kontaktieren Sie Ihren Fachhändler oder das nächste Kundendienst-Center.

Möglicherweise können wir einen Reparaturservice anbieten, falls die Rolle sich nicht mehr innerhalb der Garantie befindet. Bitte kontaktieren Sie Ihren Fachhändler oder das nächste Kundendienst-Center für weitere Details.

## Garantie moulinet Hardy

Tous les moulinets Hardy Wide Spool Perfect bénéficient d'une garantie limitée à 5 ans selon les termes présentés ci-dessous.

- La garantie fonctionne à partir du moment où le moulinet présente un défaut de fonctionnement ou un défaut au niveau de sa conception. La garantie est valable pendant 5 ans à partir de la date à laquelle vous avez acheté votre moulinet.
- Cette garantie s'ajoute à vos droits statutaires par rapport aux produits défectueux.
- Il est très important de bien enregistrer votre moulinet sur notre site Internet [www.hardyfishing.com](http://www.hardyfishing.com) dans un délai maximum de 60 jours après votre date d'achat de manière à faciliter ensuite le processus de réclamation.
- Cette garantie ne couvre pas les dommages causés en raison d'une mauvaise utilisation du moulinet, d'une négligence, d'un défaut d'entretien. Cette garantie ne couvre pas non plus l'usure normale du moulinet.
- Si vous souhaitez avoir d'autres détails plus complets sur cette garantie ainsi que sur les démarches à suivre en cas de réclamations, merci de consulter notre site Internet [www.hardyfishing.com](http://www.hardyfishing.com) ou le service client situé à proximité de chez vous.

Sachez que nous sommes aussi en mesure de vous proposer une extension de garantie au cas où votre moulinet aurait un souci à l'issu des 5 années qui ont suivi la date à laquelle vous l'avez acheté. Dans ce cas, merci de contacter le service client (détaillant) situé à proximité de chez vous pour avoir plus de détails.

## Garanzia mulinelli Hardy

Tutti i mulinelli Hardy Wide Spool Perfect sono coperti da garanzia limitata 5 anni, in base ai termini di seguito descritti:

- Garantiamo che il prodotto sia esente da difetti nel design, nella componentistica e nell'assemblaggio per un periodo di 5 anni dall'effettivo acquisto.
- Questa garanzia è addizionale rispetto alla garanzia di legge verso i prodotti difettosi.
- E' importante che avvenga la registrazione del mulinello entro 60 giorni dall'acquisto sul sito ufficiale [www.hardyfishing.com](http://www.hardyfishing.com). Riceverete una email a conferma della registrazione. Viene richiesto di conservare prova dell'acquisto (scontrino) per evitare qualsiasi problematica.
- Questa garanzia non copre danni causati da cattivo utilizzo, mancata manutenzione, negligenza o normale usura.
- Per tutti i dettagli di questa garanzia, la procedura di reclamo e le eccezioni, ti preghiamo di visitare il sito [www.hardyfishing.com](http://www.hardyfishing.com) o contattare il punto vendita autorizzato più comodo.

Saremo in grado di offrire un servizio di assistenza per i mulinelli non coperti da garanzia. Ti preghiamo di contattare il punto di assistenza ufficiale per tutti i dettagli.

## Hardy rullgaranti

Alla Hardy Wide Spool Perfect rullar innefattas av 5 års garanti enligt följande:

- Vi garanterar att produkten är felfri avseende konstruktion, material och utförande under en period av 5 år från det datum produkten först köptes.
- För att den förlängda garantin skall gälla är det är viktigt att Ni registrerar Er rulle inom 60 dagar på vår websida [www.hardyfishing.com](http://www.hardyfishing.com). Ni kommer att erhålla ett email som bekräftar Er registrering. Kunden måste kunna uppvisa inköpsbevis för att garanti skall gälla.
- Denna garanti täcker ej skador orsakade av felaktig användning, uteblivet underhåll, slarv eller normal förslitning.
- För mer information angående denna garanti var vänlig kontakta närmaste service center.

Vi kan eventuellt även erbjuda reparation om Er produkt passerat garanti perioden. Var vänlig kontakta närmaste service center för mer information.



BY APPOINTMENT TO HRH  
THE PRINCE OF WALES  
MANUFACTURERS OF  
FISHING TACKLE

**HARDY**  
ALNWICK | ENGLAND

This reel has been made by craftsmen using the best materials available to ensure its reliability. Its high quality components are precision machined with the absolute minimum susceptibility to wear or the need for future readjustment.

Given care and periodic cleaning, your reel will be a faithful servant and give you years of superb performance.

# Wide Spool Perfect

Pure Fishing, Willowburn, Alnwick, Northumberland, NE66 2PF, England  
Tel: +44 (0)1665 602771 [www.hardyfishing.com](http://www.hardyfishing.com)

Hardy, a brand from Pure Fishing, Inc.

[www.hardyfishing.com](http://www.hardyfishing.com)

## General Care

The same method of cleaning is valid for all reels in the Wide Spool Perfect reel range.

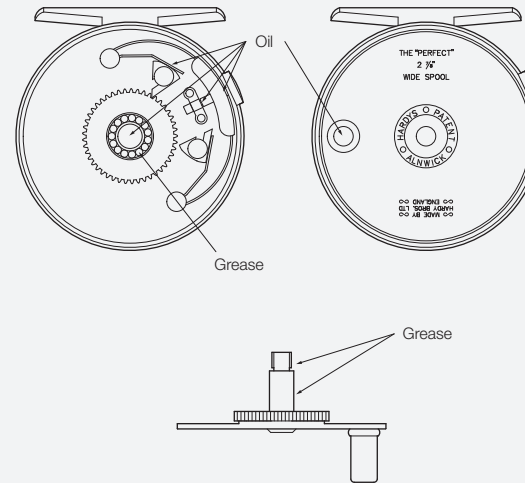

- 1— Remove line and backing.
- 2— Remove the spool.
- 3— Flush away dirt by placing the spool and frame under a stream of fresh water.
- 4— Dry carefully with a lint free cloth.
- 5— Lubricate with a good quality oil at the points illustrated on the diagrams.

- 6— Always ensure the spindle is adequately greased.
- 7— Always turn the click-check to the minimum setting to avoid compression of the springs.
- 8— Always ensure the reel and line are dry before storing in the case or pouch.

## Removing the Spool

### Spool dismantling procedure

- 1— Remove the locking screw using a good fitting coin or screwdriver, turn locking screw clockwise to remove.
- 2— Rest the palm of your hand against the face of the spool, turn

winding plate anti-clockwise to remove from spool. The spool, winding plate and frame should all be separated at this point.

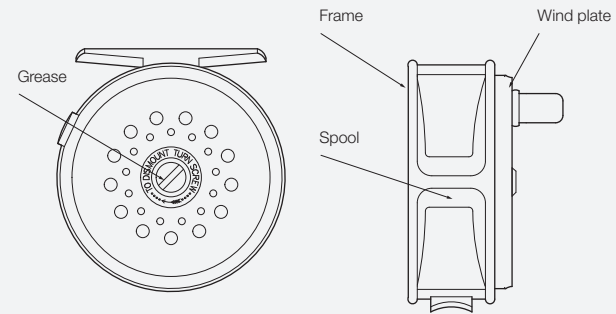

To re-assemble the spool please reverse the above dismantling procedure.

## Change your reel from left to right hand wind

All Hardy Wide Spool Perfect reels are designed to work in right or left hand wind. When you receive your reel, it will be set for left hand wind.

### To convert your reel to right hand wind:

- 1— Remove the plate and spool out of the frame by following the spool dismantling procedure described previously.
- 2— Pick up the frame so that the mechanism is visible.
- 3— Using your thumb and forefinger, switch the left hand tongue into the off position.
- 4— Using your thumb and forefinger, switch the right hand tongue into the engaged position.
- 5— Replace the plate and spool on to the frame – your reel should now be right hand wind.

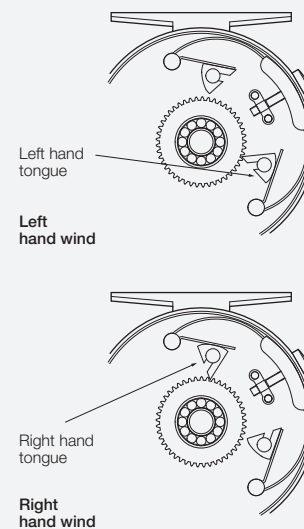

## Wide Spool Perfect click check mechanism

The click-check mechanism can be adjusted by simply turning the regulator wire on the side of the frame, anti-clockwise to increase the check, clockwise to decrease the check. When the reel is not in use, the check should be turned to the minimum setting.

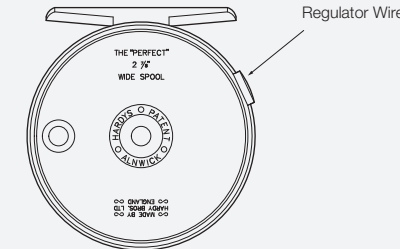

## Customer Service Centres

**Hardy Customer Service**  
Willowburn, Alnwick,  
Northumberland, NE66 2PF, England  
Tel: +44 (0)1665 602771

**Hardy Factory Service Center**  
1900 18th Street, Spirit Lake,  
IA 51360, USA.  
Tel: (888) 516-1247

## Hardy Reel Warranty

All Hardy Wide Spool Perfect reels carry a limited 5 year warranty on the terms set out below.

- We warrant that the Product will be free from material defects in design, material and workmanship for a period of 5 years from the date on which it was originally purchased.
- This warranty is in addition to your statutory rights in relation to products which are faulty or mis-described.
- It is important that you register your Reel within 60 days of purchase on our website [www.hardyfishing.com](http://www.hardyfishing.com). You will receive an email confirming your registration. Customers are requested to retain a proof of purchase in order to aid with the claims process.
- This warranty does not cover damage caused by misuse, lack of maintenance, negligence or normal wear and tear.
- For full details on this warranty, the claims process and any exclusions, please visit [www.hardyfishing.com](http://www.hardyfishing.com) or contact your nearest customer services centre.

We may be able to offer a repair service if your product falls outside the warranty period. Please contact your nearest Customer Services Centre for further details.